

# Installation instructions

## Dynamic SoundField

The following materials are included (if any are missing, contact your local Phonak dealer):

### DigiMaster 5000/7000 package

**A B C D K**

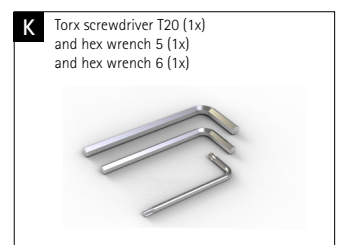
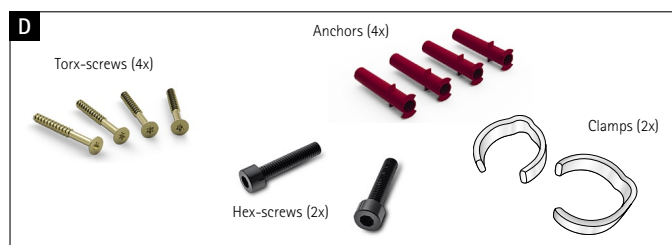
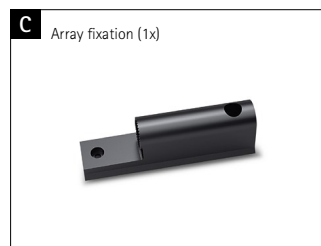
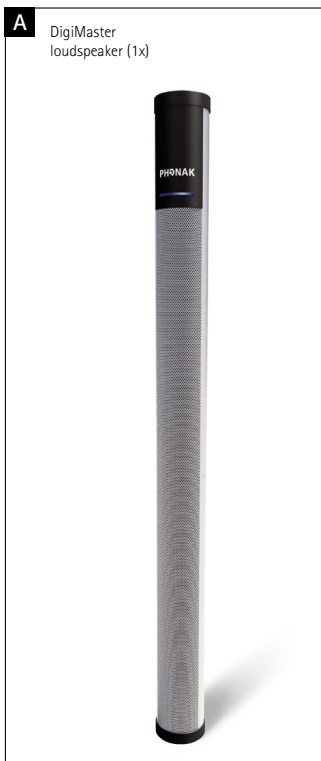
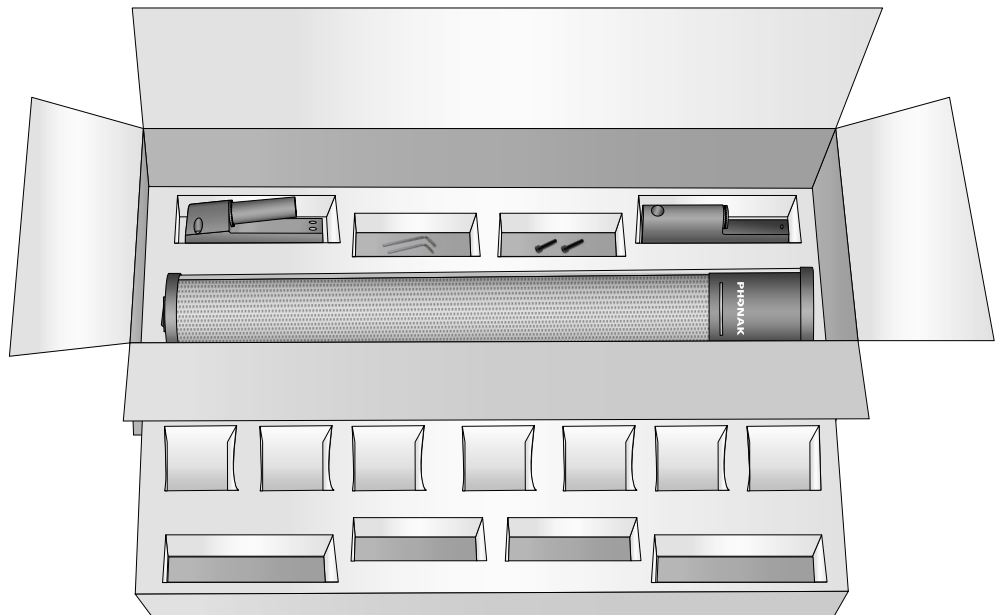

Follow these installation instructions carefully to make sure your Dynamic SoundField system is properly installed.



Dispose of the packaging material as per local regulations.

# Installation instructions

## Dynamic SoundField

### Optional: Stand tube package **I**

### Optional: Stand plate package **F G H**

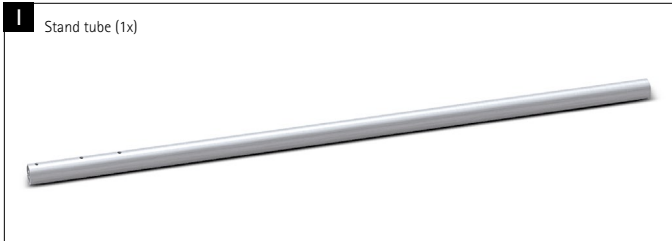
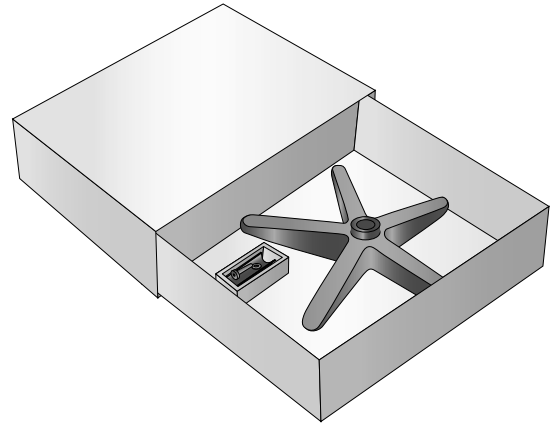
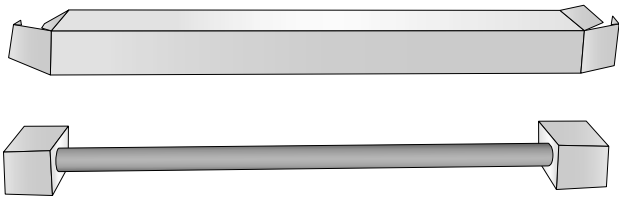

# Installation instructions

## Dynamic SoundField

The following tools are required for the installation:

To mount the loudspeaker on the floor stand:

- Hex wrench 5\*
- Hex wrench 6\*

To mount the loudspeaker on the wall:

- Drill with 5mm bit
- Spirit level
- Pencil
- Torx screwdriver T20\*
- Hex wrench 5\*

\*included in the packaging

### 1. Selecting the right location

- 1) Identify an open and safe place, ideally in front of the class, e. g. on the right or left side of the Smartboard or blackboard.

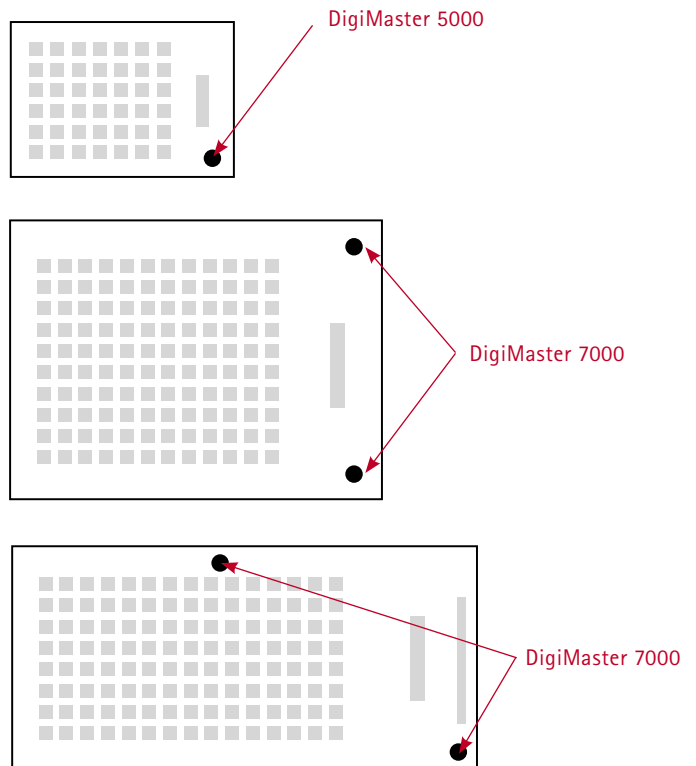

# Installation instructions

## Dynamic SoundField

### 2. Installation

#### 2.1 Mounting the DigiMaster on its stand

- 1) Take the plate [F], stand tube [I], black M8 screw [H] and M8 washer [H].
- 2) Gently place the 'screw thread' end of the tube stand in the center of the plate (see picture below). The three holes are on the upper side of the stand. Fix the tube from the underside of the plate, using the screw M8, washer and hex wrench 6. Place the stand on the floor.
- 4) Take the two black hex screws [D] from the wall mount kit and push these through the two holes in the upper part of the stand tube. Screw the DigiMaster featuring the tube connection to the tube using hex wrench 5.

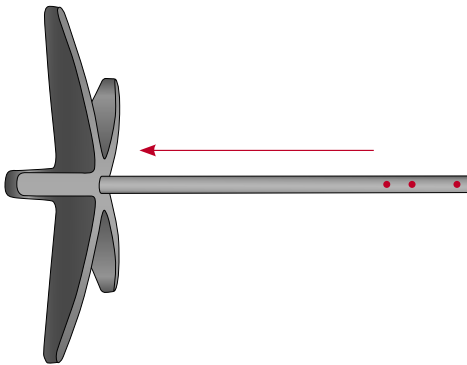

- 3) Take the DigiMaster and the tube connection [G]. Hold the tube connection behind the DigiMaster, where the 4 holes are situated. The two fingers of the tube connection should fit into the two inner holes.

- 5) Attach the power cable to the power adapter [OPTION]. Plug the power cable into the mains and the 19 Volt jack into the socket on the bottom of the DigiMaster. Your DigiMaster is now ready to be paired with inspiro.



Make sure the power cable is safely positioned!  
Do not place the power adaptor near a heater.

# Installation instructions

## Dynamic SoundField

### 2.2 Mounting DigiMaster on the wall

- 1) Measure 1.40 meters (4 feet) up from the floor level and mark the wall with a pencil.

Hold the wall support [B] against the wall so that the pencil mark is at the bottom of the wall support. Adjust the wall support using the spirit level until it is level. Use the pencil to mark the wall through the wall support's four holes.

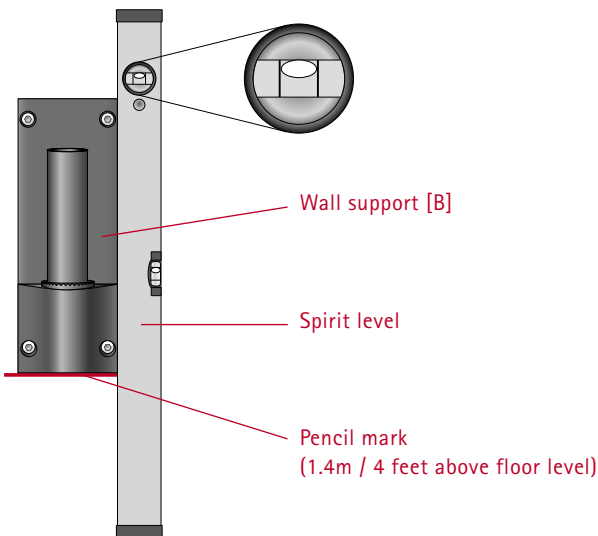

- 2) Remove the wall support and drill 4 holes using a 5 mm (0.2 inches) diameter drill bit. The depth of these holes should be at least 30 mm (1.2 inches).

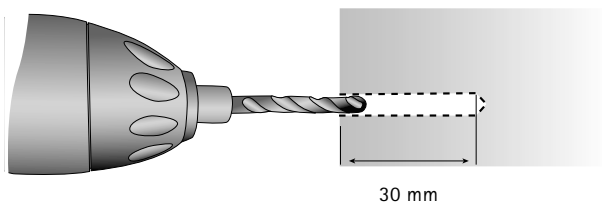

- 3) Push the anchors [D] into the holes. Mount the wall support using the 4 torx screws [D] and the torx T20 screwdriver [K].

- 4) Mount the array fixation [C] on the DigiMaster by using the two black hex screws [D] and hex wrench 5 [K].



- 5) Carefully attach the DigiMaster [A] to the wall support and turn it to face the center of the class.

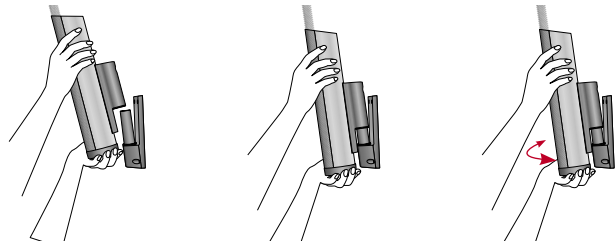

- 6) Attach the power cable to the power adapter [OPTION]. Plug the power cable into the mains and the 19 Volt jack into the socket on the bottom of the DigiMaster. Your DigiMaster is now ready to be paired with the inspiro.

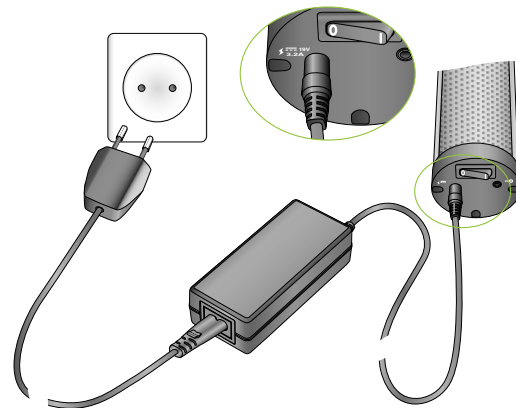

Make sure the power cable is safely positioned!



Please check the Dynamic SoundField User Guide to learn about the standard functions of Dynamic SoundField.

# Installation instructions

## Dynamic SoundField

### 3. Pairing DigiMaster with inspiro

1) Take inspiro and make sure it is charged (see the Dynamic SoundField User Guide). Switch on inspiro.

2) Use pairing procedure according to inspiro software version:

#### inspiro version 3.0 and later pairing with DigiMaster

When the battery symbol appears, press 'pairing' soft key button. inspiro will guide you through the pairing process. Please follow the instructions provided.



**How to find the inspiro software version?**  
Select "Help" and "About inspiro"

#### inspiro version 2.2 and 2.3 pairing with DigiMaster

When the battery symbol appears, press OK button and LEFT SOFTKEY (C) simultaneously as shown below, then press OK (D).

- select "Soundfield" to access the pairing menu.
- Select "Pairing". inspiro will now guide you through the pairing process. Follow the instructions provided.



**Note:**

The key combination (C and D) should be pressed within 15 seconds of the battery symbol appearing. After this time interval, the inspiro device needs to be switched off/on before repeating the key combination (C and D) or.

3) When you see three dots on the inspiro LCD, hold inspiro close to the loudspeaker (nearer than 1 meter/3 feet) and switch on the DigiMaster.

#### 4) DigiMaster 5000 loudspeaker

After a short time, inspiro will inform you that the loudspeaker has been paired. The LED color of the DigiMaster will display a constant blue light. This blue light shows that the Dynamic SoundField system is ready for operation. Dynamic SoundField's installation is complete.

#### 5) DigiMaster 7000 loudspeaker

After a short time inspiro will inform you that the loudspeaker has been paired and asked "Do you want to pair a second Dynamic SoundField?"

- If NO, the LED color of the DigiMaster will now display a constant blue light. This blue light shows that the Dynamic SoundField system is ready for operation. Dynamic SoundField's installation is complete.
- If YES, repeat the previous step for the second loudspeaker (DigiMaster 7000).
- After successfully pairing, the LED color of the second DigiMaster loudspeaker will display a constant blue light. The Dynamic SoundField system is ready for operation. Dynamic SoundField's installation is complete.

# Installation instructions

## Dynamic SoundField

### 6) Setting up a MultiTalker Network when using DigiMaster loudspeaker

**Pre-Requisite:** All secondary inspiros for MTN should not be paired with any DigiMaster loudspeaker! Before setting up MTN, select each inspiro's 'SoundField' menu then 'Disconnect'.

- 1) Pair first the initiator inspiro transmitter with the DigiMaster loudspeaker. Select 'SoundField' menu then 'Pairing'.
- 2) Use the initiator inspiro to setup MTN with secondary inspiros or transmitters. Select 'MultiTalker Network' menu then follow the instructions on the LCD

### 7) How to upgrade a DigiMaster?

- 1) Connect the mini-USB cable to the DigiMaster mini-USB on the loudspeaker top as depicted.
- 2) Connect the cable with a computer running Digiware software – the updater software for Dynamic SoundField systems
- 3) Select firmware upgrade and follow the instructions displayed on the computer screen.

